

LOOP Evotec G4 FW, LW & HD Fly Reel Manual

Congratulations on the purchase of your new flyreel. We wish you many seasons of good use of your new reel in flyfishing. Enclosed are instructions for proper care and maintenance. Good luck!

Conversion left / right hand retrieve:

1. Remove spoolcap (27).
2. Pull spool (25) straight out.
3. Release stopscrews (2) ½ turn with enclosed Allen wrench.
4. Pull drag knob (1) straight out.
5. Remove drag knob nut (3).
6. Pull draw bar (24) straight out, together with cup springs (23).
7. Pull bearing holder (22) straight from shaft (15).
8. Remove seal ring (16).
9. Remove bearing (17), bearing washers (18), carbon plates (21) and one way bearing (20).
10. Turn one way bearing (20).
11. Wipe clean.
12. Assemble the reverse way.

- | | |
|-----------------------|---------------------------------|
| 1. Drag knob | 19. Ball bearing |
| 2. Locking screw M3x5 | 20. One way clutch ass'y |
| 3. Drag knob nut | 21. Carbon plate |
| 4. O-ring | 22. Bearing holder |
| 5. Nut washer | 23. Cup spring |
| 6. Click bush | 24. Draw bar |
| 7. Click pin | 25. Spool |
| 8. Click spring | 26. Spool cap o-ring |
| 9. Stop pin | 27. Spool cap |
| 10. - | 28. Handle rivet, balance screw |
| 11. Housing | 29. Handle rivet |
| 12. Foot | 30. Handle knob washer |
| 13. Foot screw | 31. Handle knob |
| 14. - | 32. Handle knob screw |
| 15. - | 33. Balance |
| 16. Seal ring | 34. Balance o-ring |
| 17. Ball bearing | |
| 18. Steel plate | |

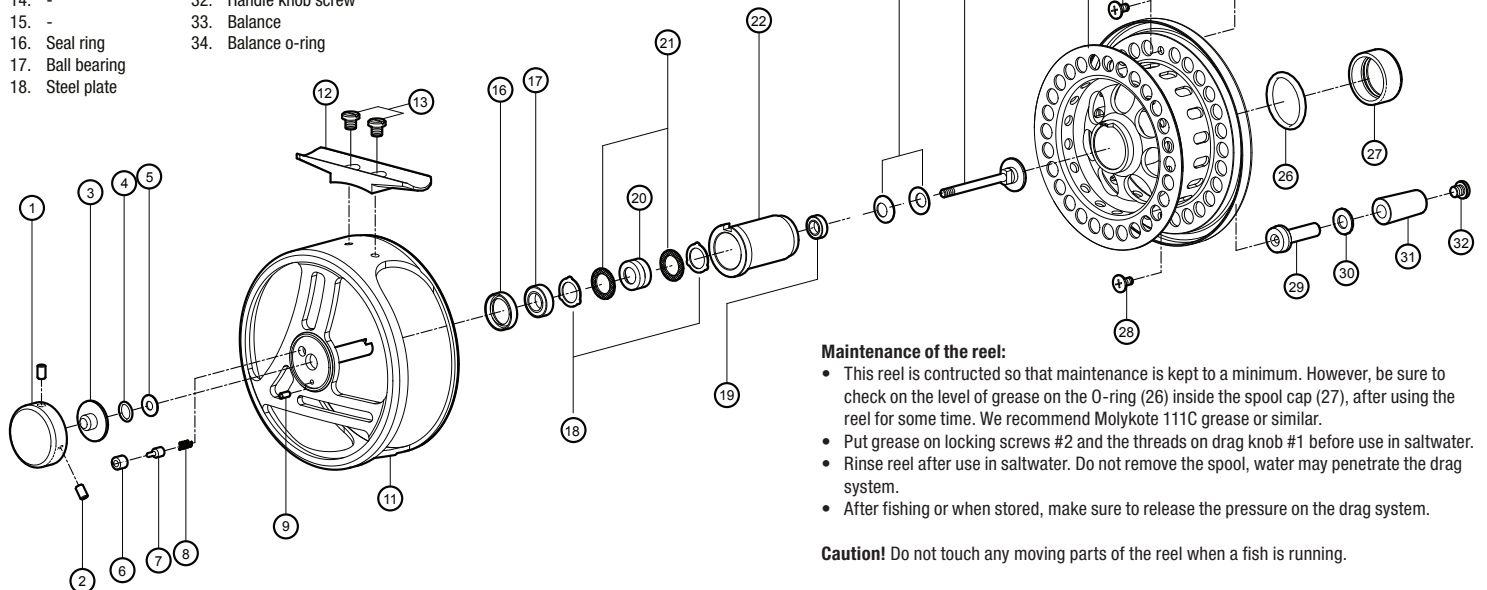

Adjust the effect of the brake:

The drag knob nut (3) allows you to adjust the brake, in order to obtain the lowest brake effect of preference. We recommend free spool in both directions.

1. Turn the adjustment screw (3) until the lowest preferred brake effect has been obtained.
2. Fasten the drag knob to the adjustment screw and turn the handle counter clockwise so that the heel on the inside of the drag knob (36) will settle to the left of the stop pin (9). Tighten the screws on the lock with the Allen wrench.

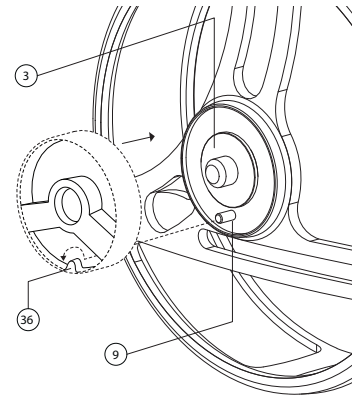

Maintenance of the reel:

- This reel is constructed so that maintenance is kept to a minimum. However, be sure to check on the level of grease on the O-ring (26) inside the spool cap (27), after using the reel for some time. We recommend Molykote 111C grease or similar.
- Put grease on locking screws #2 and the threads on drag knob #1 before use in saltwater.
- Rinse reel after use in saltwater. Do not remove the spool, water may penetrate the drag system.
- After fishing or when stored, make sure to release the pressure on the drag system.

Caution! Do not touch any moving parts of the reel when a fish is running.